

HP Integral

Smart  Flow  Plus 
solutions to meet your needs



HP Integral

Smart  Flow  Plus 
solutions to meet your needs



HP Integral is an innovative **motor-drive integration** that combines a **PM (permanent magnet) synchronous motor with a VFD (Variable Frequency Drive)**, achieving very **High Efficiency** levels.



The motor range leverages both brushless servo motor and AC induction motor technologies, so enhancing the power density and allowing for significant **size and weight reductions up to 50%**.

The drive is fully integrated with the motor into a dedicated case, so granting a very compact design and further reducing overall dimensions and weight.

Several drive configurations are available to cover a wide range of industrial and commercial applications: **variable torque applications**, typically in HVAC, as well as **constant torque applications** like material handling, air compressors and vacuum pumps.



RANGE OVERVIEW

PRODUCT LINE	FEATURES	FRAME SIZE	TORQUE		MAIN APPLICATIONS
			CONSTANT	VARIABLE	
HP Integral	<ul style="list-style-type: none"> • Single-phase supply voltage • Easy-to-use built-in keypad as option 	71		✓	<ul style="list-style-type: none"> • HVAC
HP Integral Smart 	<ul style="list-style-type: none"> • Smart configuration • Suitable for most applications • Industrial, Pump & Fan modes 	90-112	✓	✓	<ul style="list-style-type: none"> • General Industrial • HVAC
HP Integral Flow 	<ul style="list-style-type: none"> • Dedicated control functions for HVAC • Innovative energy saving features • Flexible functionality 	90-112		✓	<ul style="list-style-type: none"> • Advanced HVAC
HP Integral Plus 	<ul style="list-style-type: none"> • Advanced configuration • Maximum performance, motor control • Built in PLC capability 	90-112	✓	✓	<ul style="list-style-type: none"> • Demanding Industrial • Compressors • Vacuum pumps • Material handling

SAVING ENERGY WITH HP INTEGRAL

Electric motors have a significant impact on the worldwide energy consumption:

→ **up to 75% in industrial application and 40% in commercial application***

Today, a major factor influencing the motor industry is energy efficiency driven by both increasingly demanding legislation and the industry's

greater awareness of environmental responsibility.

Lafert embraces the challenge! With HP Integral, saving energy and reducing costs are possible with three easy steps:

- 1. INCREASED MOTOR EFFICIENCY**
- 2. SPEED CONTROL BY A VFD**
- 3. SYSTEM OPTIMISATION**

2. SPEED CONTROL BY VFD

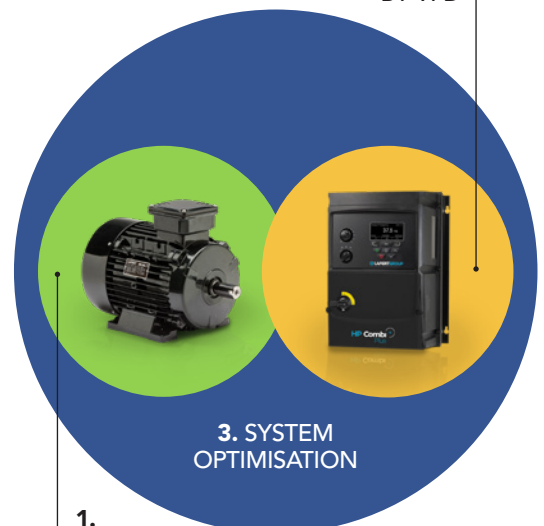

1. INCREASED MOTOR EFFICIENCY

* Source: International Energy Agency

ADDED VALUES & BENEFITS

MOTOR-DRIVE SYSTEM FULLY DIMENSIONED AND CONFIGURED

according to customer needs

INCREASED SYSTEM EFFICIENCY & SHORT PAYBACK TIME

thanks to speed control and motor-drive optimisation

ADVANCED CONTROL ELECTRONICS

PC and mobile tools for easy commissioning, control and service



COMPACT DESIGN

thanks to the built-in drive

THREE MOTOR-DRIVE CONFIGURATIONS

to cover both variable and constant torque applications



ONE SINGLE SOURCE

for both motor and drive

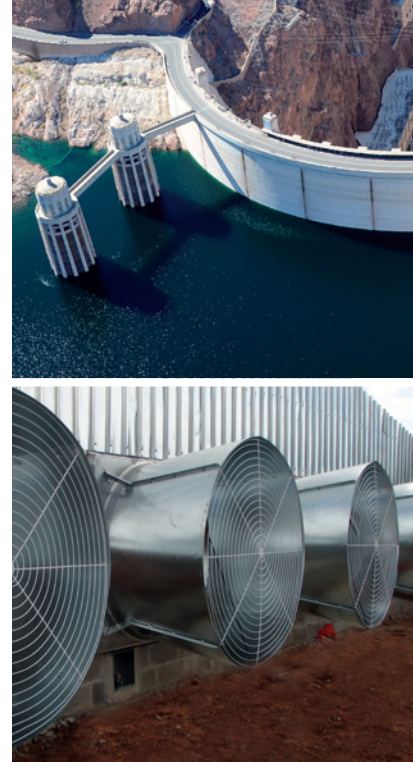

STANDARDS & REGULATIONS

	EFFICIENCY TESTING METHOD	EFFICIENCY CLASSIFICATION	IE CODE						
			IEC STANDARD		EU MEPS	HP INTEGRAL			
MOTOR	IEC 60034-2-1	IEC 60034-30-2	IE1	IE2	IE3	IE4	IE5	IE3	IE5
VFD	IEC 61800-9-2:VFD Classification and testing		IE0	IE1	IE2			IE2	IE2
MOTOR + VFD	IEC 61800-9-2:VFD Classification and testing		IES0	IES1	IES2				IES2



1. INCREASED MOTOR EFFICIENCY

PM (permanent magnet) Synchronous Motors offer improved electrical efficiency when compared to traditional AC motors, achieving **IE4 and IE5 efficiency levels**.

PM technology benefits:

- **HIGH EFFICIENCY ACROSS A WIDE RANGE OF OPERATING SPEEDS**
- **EXCELLENT POWER DENSITY AND TORQUE CAPABILITY**



2. SPEED CONTROL BY VFD

A Variable Frequency Drive (VFD) is used to adjust the speed and torque of motor according to the variable demand of an application.

This results in a **relevant decrease in energy consumption** that leads to a **remarkable improvement in overall process efficiency**.

70% of applications are suitable for speed control. Typical variable torque applications, like **fans, compressors and pumps**, will benefit considerably from speed control:

SPEED REDUCTION OF 20% RESULTS IN UP TO 50% ENERGY REDUCTION



3. SYSTEM OPTIMISATION

The motor-drive system is **fully dimensioned and configured in accordance with the application's needs** and the customer's requirements.

Each motor-drive system is unique and designed for the purpose.

This results in a **PLUG & PLAY solution**, with a wide range of optimised motor-drive configurations for **fast set-up and easy commissioning**.

One single source for both system's components, motor and drive, makes this possible!

Type	Rated Speed	Rated Power	Rated Torque	Peak Torque	Motor Rated Current	Motor Peak Current	Rated input current		Torque Constant	Weight HPI	Efficiency HPI		
							380Vac	480Vac			Smart	Flow	Plus
							n [rpm]	Pn [kW]			Mn [Nm]	Mpk [Nm]	In [Arms]
1500 rpm													
HPI90 1500 32	1500	1.5	9.6	14.4	3.2	4.8	3.4	2.7	3	13.5	88.3	88.5	87.6
HPI90 1500 47	1500	2.2	14.0	21.0	4.7	7.0	4.9	3.9	3	15.5	89.7	89.4	88.7
HPI90 1500 64	1500	3	19.1	28.7	6.4	9.6	6.6	5.2	3	17.5	90.4	90.1	90.2
HPI112 1500 85	1500	4	25.5	38.3	8.5	12.7	8.7	6.9	3	28.5	91.2	90.8	90.7
HPI112 1500 117	1500	5.5	35.0	52.5	11.7	17.5	11.9	9.4	3	31.5	92.0	92.2	91.5
HPI112 1500 159	1500	7.5	47.8	71.7	15.9	23.9	16.2	12.8	3	35.5	92.7	92.8	92.0
1800 rpm													
HPI90 1800 32	1800	1.5	8.0	11.9	3.2	4.8	3.4	2.7	2.5	13.5	88.7	88.9	88.0
HPI90 1800 46	1800	2.2	11.7	17.5	4.6	7.0	4.9	3.9	2.5	15.5	89.9	89.6	89.0
HPI90 1800 63	1800	3	15.9	23.9	6.3	9.5	6.6	5.2	2.5	17.5	90.6	90.3	90.4
HPI90 1800 84	1800	4	21.2	31.8	8.4	12.7	8.8	7.0	2.5	20.5	91.4	90.9	90.8
HPI112 1800 84	1800	4	21.2	31.8	8.4	12.7	8.7	6.9	2.5	28.5	91.4	90.9	90.8
HPI112 1800 116	1800	5.5	29.2	43.8	11.6	17.4	11.9	9.4	2.5	31.5	92.1	92.4	91.6
HPI112 1800 158	1800	7.5	39.8	59.7	15.8	23.8	16.2	12.8	2.5	35.5	92.9	92.9	92.2
HPI112 1800 232	1800	11	58.4	87.5	23.2	34.9	23.6	18.7	2.5	38.5	93.5	92.9	92.5
3000 rpm													
HPI90 3000 47	3000	2.2	7.0	10.5	4.7	7.0	4.8	3.8	1.5	13.5	88.7	88.9	88.0
HPI90 3000 64	3000	3	9.6	14.4	6.4	9.6	6.4	5.1	1.5	15.5	89.9	89.6	89.0
HPI90 3000 85	3000	4	12.7	19.1	8.5	12.7	8.5	6.8	1.5	17.5	90.6	90.3	90.4
HPI90 3000 117	3000	5.5	17.5	26.3	11.7	17.5	11.7	9.3	1.5	19.5	91.4	90.9	90.8
HPI112 3000 117	3000	5.5	17.5	26.3	11.7	17.5	11.9	9.4	1.5	28.5	91.4	90.9	90.8
HPI112 3000 159	3000	7.5	23.9	35.9	15.9	23.9	15.9	12.5	1.5	31.5	92.1	92.4	91.6
HPI112 3000 233	3000	11	35.0	52.5	23.3	35.0	23.2	18.4	1.5	35.5	92.9	92.9	92.2
HPI112 3000 318	3000	15	47.8	71.7	31.8	47.8	31.5	25.0	1.5	38.5	NA	92.9	NA
3600 rpm													
HPI90 3600 46	3600	2.2	5.8	8.8	4.6	7.0	4.8	3.8	1.26	13.5	88.0	87.9	87.6
HPI90 3600 63	3600	3	8.0	11.9	6.3	9.5	6.4	5.1	1.26	15.5	89.0	88.8	88.8
HPI90 3600 84	3600	4	10.6	15.9	8.4	12.7	8.5	6.8	1.26	17.5	89.6	89.7	90.0
HPI90 3600 116	3600	5.5	14.6	21.9	11.6	17.4	11.7	9.3	1.26	19.5	90.6	90.8	90.7
HPI112 3600 116	3600	5.5	14.6	21.9	11.6	17.4	11.9	9.4	1.26	28.5	93.5	92.1	92.7
HPI112 3600 158	3600	7.5	19.9	29.8	15.8	23.8	15.9	12.5	1.26	31.5	93.9	93.6	92.9
HPI112 3600 232	3600	11	29.2	43.8	23.2	34.9	23.2	18.4	1.26	35.5	94.0	93.6	93.6
HPI112 3600 317	3600	15	39.8	59.7	31.7	47.5	31.5	25.0	1.26	38.5	NA	94.5	NA
4500 rpm													
HPI90 4500 64	4500	3	6.4	9.6	6.4	9.6	6.4	5.1	1	13.5	88.7	88.9	88.0
HPI90 4500 85	4500	4	8.5	12.7	8.5	12.7	8.5	6.8	1	15.5	89.9	89.6	89.0
HPI90 4500 117	4500	5.5	11.7	17.5	11.7	17.5	11.7	9.3	1	17.5	90.6	90.3	90.4
HPI90 4500 159	4500	7.5	15.9	23.9	15.9	23.9	15.9	12.6	1	20.5	91.4	90.9	90.8



HPI RANGE

IES2 c  US

- Power rating: 0.55kW to 15kW - 0.75HP to 20HP
- Torque: 2 Nm to 60 Nm
- Speed: up to 4500 rpm
- Frame size: 71, 90, 112
- Three-phase Supply Voltage: 200-230V, 380-480V, 500-600V
- Single-phase Supply Voltage (only frame size 71): 200-240V
- Three drive series – **Smart, Flow, Plus** – to satisfy any application requirements (only frame size 90 112)
- **Design flexibility**
- PC tool and mobile app for easy set up (only frame size 90 - 112)

HP Drive  TOOLS

MAIN SUPPLY

Supply Frequency	48-62 Hz	48-62Hz	48-62Hz
Three-phase Supply Voltage	200-240 V ± 10%	200-240 V ± 10%	200-240 V ± 10%
	380-480 V ± 10%	380-480 V ± 10%	380-480 V ± 10%
		500-600 V ± 10%	500-600 V ± 10%

OUTPUT RATINGS

Power Ratings	Up to 11 kW	Up to 15 kW	Up to 11 kW
Overload Capacity	150% for 60 seconds	110% for 60 seconds	150% for 60 seconds
	175% for 2.5 seconds	165% for 4 seconds	200% for 4 seconds

PROGRAMMABLE INPUTS

2 Digital	3 Digital (+3 optional)	3 Digital (+3 optional)
2 Analog / Digital selectable	2 Analog / Digital selectable	2 Analog / Digital selectable

PROGRAMMABLE OUTPUTS

1 Analog / Digital	2 Analog / Digital	2 Analog / Digital
1 Relay	2 Relays (+3 optional)	2 Relays (+3 optional)

BUILT IN FIELDBUS

CANopen	BACnet MS/TP	CANopen
Modbus RTU	Modbus RTU	Modbus RTU
Other options available	Other options available	Other options available

INTERNAL EMC FILTER

✓	✓*	✓*
---	----	----

INTERNAL BRAKE TRANSISTOR

✓**	NA	✓
-----	----	---

ENCLOSURE

Switched or non-switched	With or without disconnecter	Switched or non-switched
--------------------------	------------------------------	--------------------------

PI(D) CONTROL

Internal PI controller	Internal PID controller	Internal PID controller
Standby / sleep function	STO function	STO function
	Programmable PLC	Programmable PLC
	Multi setpoint select	Multi setpoint select
	Standby / sleep function	Standby / sleep function

* Not available for 500-600V drives

** Not available in size 1

MOTOR RANGE
IE5 IP55

- Ultra Premium Efficiency – IE5
- IEC mechanical configurations (B14, B5,...)
- NEMA mounting
- Degree of protection IP55 as standard
- Size and weight reduction up to 50%

DRIVE RANGE
IE2 IP66

- Dedicated PM motor vector control
- IP66 / NEMA 4X Outdoor
- Conformally coated electronics for harsh environments
- High Efficiency - IE2



PERFORMANCE DATA | HPI 71

HP Integral 71 is available also as single-phase design @ 230 V. For values @ 230 V, please contact us.

Type	Rated Speed	Rated Power	Rated Torque	Peak Torque	Motor Rated Current	Motor Peak Current	Rated input current		Torque Constant	Weight HPI	Efficiency HPI
							380Vac	480Vac			
	n [rpm]	Pn [kW]	Mn [Nm]	Mpk [Nm]	In [Arms]	Ipk [Arms]	lin [Arms]	lin [Arms]	Kt [Nm/A]	[kg]	η [%]
1500 rpm											
HPI71 1500 12	1500	0.55	3.5	5.3	1.2	1.8	1.3	1.0	3	7.3	81.1%
HPI71 1500 16	1500	0.75	4.8	7.2	1.6	2.4	1.7	1.4	3	7.9	81.8%
HPI71 1500 23	1500	1.1	7.0	10.5	2.3	3.5	2.5	2.0	3	8.7	83.0%
HPI71 1500 32	1500	1.5	9.6	14.4	3.2	4.8	3.4	2.7	3	9.5	83.6%
1800 rpm											
HPI71 1800 12	1800	0.55	2.9	4.4	1.2	1.7	1.3	1.0	2.5	7.3	83.3%
HPI71 1800 16	1800	0.75	4.0	6.0	1.6	2.4	1.7	1.4	2.5	7.9	84.9%
HPI71 1800 23	1800	1.1	5.8	8.8	2.3	3.5	2.5	2.0	2.5	8.7	85.3%
HPI71 1800 32	1800	1.5	8.0	11.9	3.2	4.8	3.4	2.7	2.5	9.5	85.8%
3000 rpm											
HPI71 3000 16	3000	0.75	2.4	3.6	1.6	2.4	1.7	1.3	1.5	7.3	85.5%
HPI71 3000 23	3000	1.1	3.5	5.3	2.3	3.5	2.4	1.9	1.5	7.9	86.9%
HPI71 3000 32	3000	1.5	4.8	7.2	3.2	4.8	3.3	2.6	1.5	8.5	87.4%
HPI71 3000 47	3000	2.2	7.0	10.5	4.7	7.0	4.8	3.8	1.5	9.1	87.7%
3600 rpm											
HPI71 3600 16	3600	0.75	2.0	3.0	1.6	2.4	1.7	1.3	1.26	7.3	86.4%
HPI71 3600 23	3600	1.1	2.9	4.4	2.3	3.5	2.4	1.9	1.26	7.9	87.2%
HPI71 3600 32	3600	1.5	4.0	6.0	3.2	4.8	3.3	2.6	1.26	8.5	87.9%
HPI71 3600 46	3600	2.2	5.8	8.8	4.6	7.0	4.8	3.8	1.26	9.1	88.1%
4500 rpm											
HPI71 4500 23	4500	1.1	2.3	7.0	2.3	3.5	2.4	1.9	1	7.3	86.4%
HPI71 4500 32	4500	1.5	3.2	3.5	3.2	4.8	3.3	2.6	1	7.9	87.3%
HPI71 4500 47	4500	2.2	4.7	6.8	4.7	7.0	4.8	3.8	1	8.7	88.1%
HPI71 4500 64	4500	3	6.4	7.1	6.4	9.6	6.5	5.1	1	9.5	88.2%

VARIABLE FREQUENCY DRIVE (VFD) | SPECIFICATIONS HPI 71

HP Integral

MAIN SUPPLY

Supply Frequency	48-62 Hz
Single-phase Supply Voltage	200-240 V \pm 10%
Three-phase Supply Voltage	200-230 V \pm 10%
	380-480 V \pm 10%

OUTPUT RATINGS

Power Ratings	Up to 2.2 kW
Overload Capacity	150% for 60 seconds

PROGRAMMABLE INPUTS / OUTPUTS

2 Analog Inputs
2 Digital Inputs
2 Analog Outputs
2 Digital Outputs
2 Relays

BUILT IN FIELDBUS

Modbus RTU
Other options available

INTERNAL EMC FILTER

✓



DIMENSIONS FRAME SIZE 71 - 90 - 112 IM B3 ALUMINIUM ALLOY FRAME

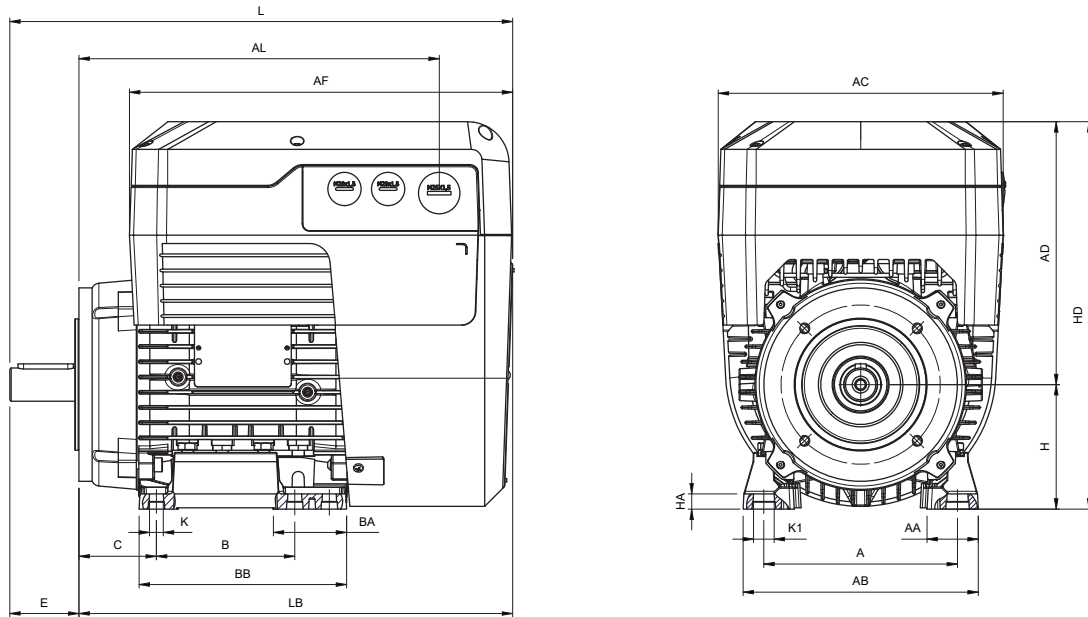

IEC	H	A	B	C	K ¹⁾	AB	BB	AD ²⁾	HD ²⁾	AC	HA
71	71	112	90	45	8	135	108	160	231	174	8.5
90 Smart	90	140	100	56	10	170	150	190	280	206	11
90 Flow - Plus	90	140	125	56	10	170	150	213	303	206	11
112 Smart	112	190	140	70	12.5	220	176	226	338	241	15
112 Flow - Plus	112	190	140	70	12.5	220	176	251	363	241	15

IEC	K1	L	LB	AL	AF	BA	AA	D	E	F	GD	GA	DB ³⁾
71	11	275	235	182	211	28	31	19	40	6	6	22	M6
90 Smart - Flow - Plus	15	363	277	260	313	28/53	37	24	50	8	7	27	M8
112 Smart - Flow - Plus	19	439	332	326	379	46	48	28	60	8	7	31	M10

1) Clearance hole for screw

2) Maximum distance

3) Centering holes in shaft extensions to DIN 332 part 2

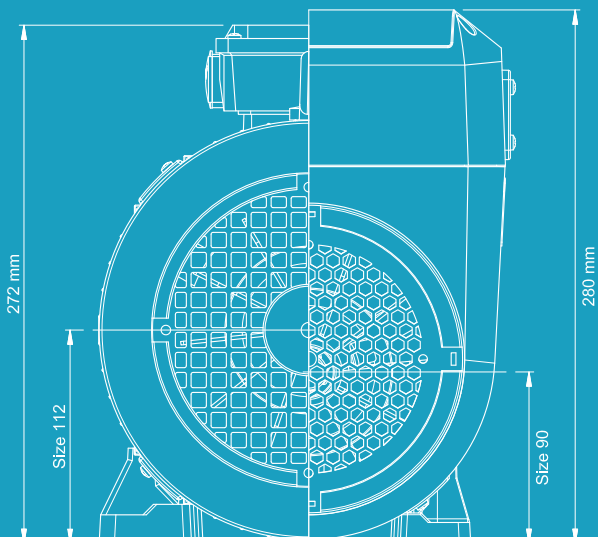

HEIGHT COMPARISON | HPI 90 VS AC 112

AC MOTOR	HPI MOTOR
SIZE 112 - 5.5 KW 34 KG	SIZE 90 - 5.5 KW 19.5 KG
SIZE 132 - 7.5 KW 53 KG	SIZE 112 - 7.5 KW 31.5 KG

Lafert S.p.A.

Via J.F. Kennedy,43
30027 San Donà di Piave (Venice), Italy
Tel. +39 / 0421 229 611
lafert.info@shi-g.com

www.lafert.com

Branches & Partners**Lafert GmbH**

Wolf-Hirth-Straße 10
71034 Böblingen
Germany
Phone +49 175 550 4526
lge.info@shi-g.com

Lafert Electric Motors Ltd.

Unit 17 Orion Way
Crewe, Cheshire CW1 6NG
United Kingdom
Phone +44 / (0) 1270 270 022
luk.info@shi-g.com

Lafert Moteurs S.A.S.

L'Isle d'Abeau Parc de Chesnes
75, rue de Malacombe
38070 St. Quentin-Fallavier
France
Phone +33 / 474 95 41 01
lfr.info@shi-g.com

Lafert Motores Electricos, S.L.U.

Poligono Pignatelli, Nave 27
50410 Cuarte de Huerva (Zaragoza)
Spain
Phone +34 / 976 503 822
les.info@shi-g.com

Lafert N.A. (North America)

5620 Kennedy Road - Mississauga
Ontario L4Z 2A9
Canada
Phone +1 / 800/661 6413 - 905/629 1939
lna.info@shi-g.com

Lafert Electric Motors (Australia)

Factory 3, 117-123 Abbott Road,
Hallam - VIC 3803
Australia
Phone +61 / (0)3 95 46 75 15
info@lafertaustr.com.au

Lafert Singapore Pte Ltd

48 Hillview Terrace #06-06
Hillview Building - Singapore 669269
Phone +65 / 67630400 - 67620400
info@lafert.com.sg

Lafert (Suzhou) Co., Ltd.

No.3 Industrial Plant Building Yue Xi Phase 3,
Tian E Dang Lu 2011, 215104 Wuzong
Economic Development Zone, Suzhou
China
Phone +86 / 512 6687 0618
lsu.info@shi-g.com